

Reservoir, Series AS2-CLS/ -CLP/ -CLC

- for filters, pre-filters and microfilters
- Material Polycarbonate Die cast zinc
- suitable for ATEX



Type	Reservoir
Certificates	suitable for ATEX
Working pressure min./max.	16 bar
Ambient temperature min./max.	-10 ... 50 °C
Medium temperature min./max.	-10 ... 50 °C
Medium	Compressed air
Filter reservoir volume	28 cm ³
Weight	See table below

Technical data

Part No.	Condensate drain	Reservoir
R412006338	semi-automatic, open without pressure	Polycarbonate
R412006339	fully automatic, open without pressure	Polycarbonate
R412006340	fully automatic, closed without pressure	Polycarbonate
R412006344	semi-automatic, open without pressure	Die cast zinc, with window
R412006345	fully automatic, open without pressure	Die cast zinc, with window
R412006346	fully automatic, closed without pressure	Die cast zinc, with window

Part No.	Protective guard	Weight	Fig.
R412006338	Polyamide	0,077 kg	Fig. 1
R412006339	Polyamide	0,12 kg	Fig. 2
R412006340	Polyamide	0,12 kg	Fig. 2
R412006344	-	0,338 kg	Fig. 1
R412006345	-	0,39 kg	Fig. 2
R412006346	-	0,39 kg	Fig. 2

Suitable for use in Ex zones 1, 2, 21, 22.

Technical information

Material	
Reservoir	Polycarbonate Die cast zinc
Protective guard	Polyamide
Seal	Acrylonitrile butadiene rubber

Dimensions

Dimensions in mm, Fig. 1

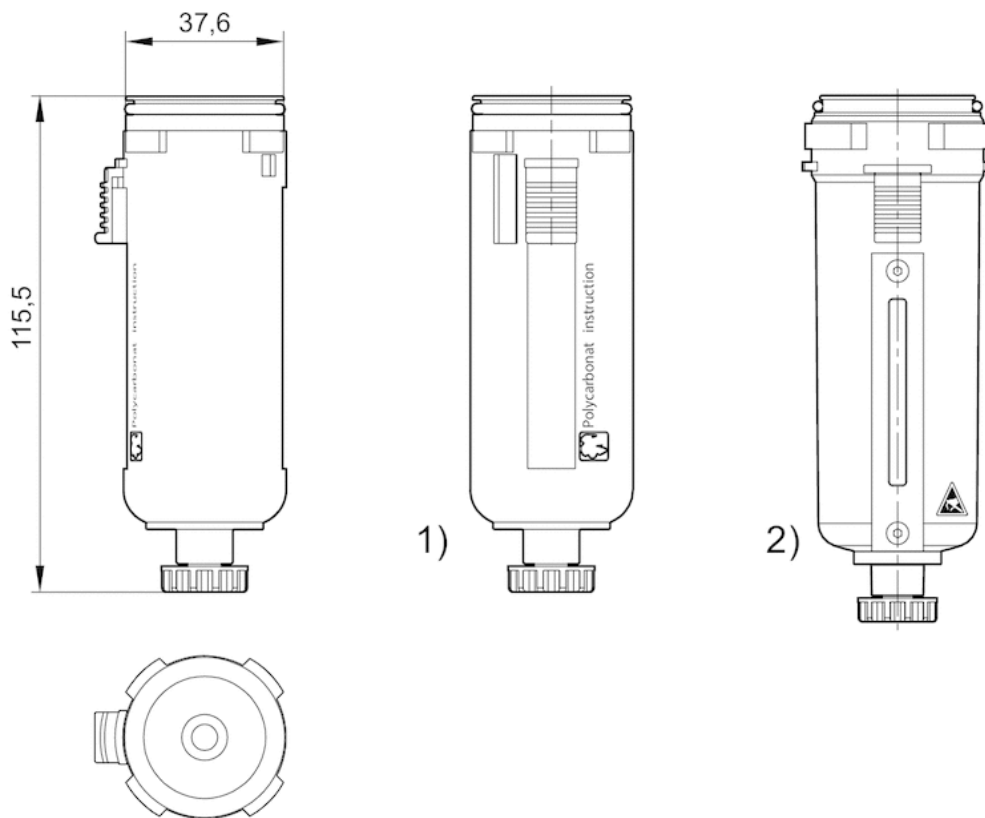

- 1) Plastic reservoir and protective guard with window
- 2) Metal reservoir with inspection glass

Dimensions in mm, Fig. 2

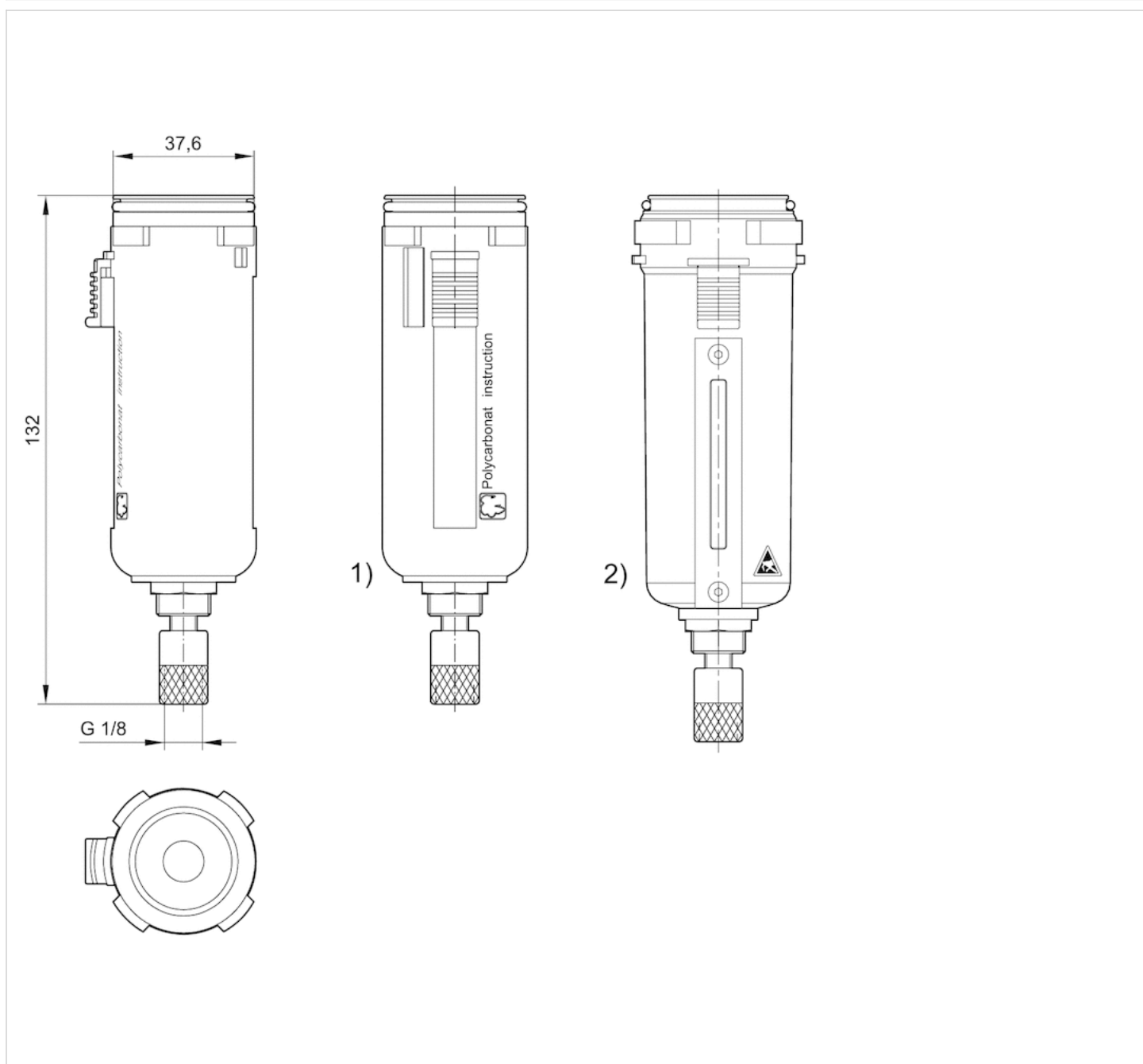

- 1) Plastic reservoir and protective guard with window
- 2) Metal reservoir with inspection glass

Efficient pneumatic solutions, our program: cylinders and drives, valves and valve systems, air supply management



Visit us: [Emerson.com/Aventics](https://www.emerson.com/Aventics)

Your local contact: [Emerson.com/contactus](https://www.emerson.com/contactus)



Emerson.com



[Facebook.com/EmersonAutomationSolutions](https://www.facebook.com/EmersonAutomationSolutions)



[LinkedIn.com/company/Emerson-Automation-Solutions](https://www.linkedin.com/company/Emerson-Automation-Solutions)



[Twitter.com/EMR_Automation](https://twitter.com/EMR_Automation)

An example configuration is depicted on the title page. The delivered product may thus vary from that in the illustration. Subject to change. This Document, as well as the data, specifications and other information set forth in it, are the exclusive property of AVENTICS GmbH. It may not be reproduced or given to third parties without its consent. Only use the AVENTICS products shown in industrial applications. Read the product documentation completely and carefully before using the product. Observe the applicable regulations and laws of the respective country. When integrating the product into applications, note the system manufacturer's specifications for safe use of the product. The data specified only serve to describe the product. No statements concerning a certain condition or suitability for a certain application can be derived from our information. The information given does not release the user from the obligation of own judgement and verification. It must be remembered that the products are subject to a natural process of wear and aging.

The Emerson logo is a trademark and service mark of Emerson Electric Co. Brand logotype are registered trademarks of one of the Emerson family of companies. All other marks are the property of their respective owners. © 2020 Emerson Electric Co. All rights reserved.
2020-12



CONSIDER IT SOLVED™